

| 插针数 Contacts | 料号 Order No. | 产品代号 Part Code | 电缆直径(D) Cable outlet | 重量 Weight |
|-----------------|-----------------|-------------------|-------------------------|--------------|
| 3 | 1630034213101 | M12P-F03A-T-D6 | 4-6mm | 27.9g |
| | 1630034213102 | M12P-F03A-T-D8 | 6-8mm | 27.7g |
| | 1630044213101 | M12P-F04A-T-D6 | 4-6mm | 28.6g |
| 4 | 1630044213102 | M12P-F04A-T-D8 | 6-8mm | 28.4g |
| | 1630054213101 | M12P-F05A-T-D6 | 4-6mm | 30.4g |
| 5 | 1630054213102 | M12P-F05A-T-D8 | 6-8mm | 30.2g |

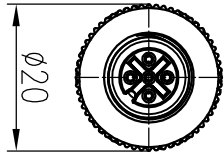

针位排布图
Contact arrangement

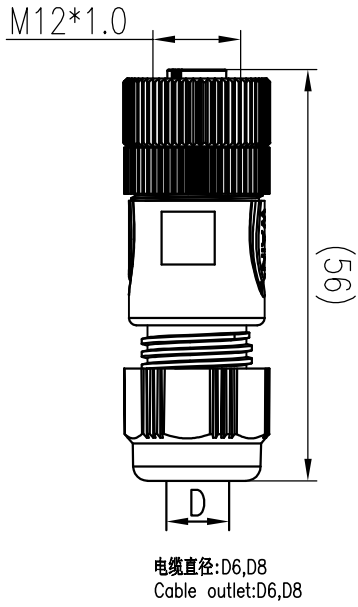
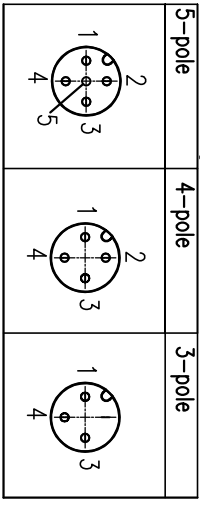

- 技术参数:
- 产品系列: M12-A 编码
 - 插针数: 3 4 5
 - 额定电流(40°C): 4A 4A 4A
 - 额定电压: 250V 250V 125V
 - 额定脉冲电压: 2500V 2500V 1500V
 - 污染等级: 3
 - 接触电阻: ≤10mΩ
 - 防护等级: IP67
 - 插接次数: >100
 - 温度范围: -40°C...+85°C
 - 绝缘阻抗: >100MΩ
 - 接线方式: 螺钉锁紧
 - 线径范围: max:0.75mm² (max:AWG18)
 - 锁紧扭矩: 0.2Nm (螺钉接线)
 - 电缆直径: 4-6mm,6-8mm
 - 电焊剥线长度: 20mm
 - 导线剥线长度: 5mm
- 材料特性:
- 锁紧螺母: 塑料
 - 插针材料: 铜合金
 - 插针表面处理: 镀金
 - 外壳材料: PA
 - 颜色: RAL 9005 (黑色)
 - 绝缘材料: PA
- 符合标准: IEC 61076-2-101
- Technical specification:
- Series: M12 A-Code
 - Number of contacts: 3 4 5
 - Rated current(40°C): 4A 4A 4A
 - Rated voltage: 250V 250V 125V
 - Rated impulse voltage: 2500V 2500V 1500V
 - Pollution degree: 3
 - Contact resistance: ≤10mΩ
 - Degree of protector: IP67
 - Mating cycles: >100
 - Temperature range: -40°C - +85°C
 - Insulation resistance: >100MΩ
 - Termination method: screw connection
 - Wire gauge: max:0.75mm² (max:AWG18)
 - Torque: 0.2Nm (screw terminal blocks)
 - Cable Outlet: 4~6mm,6-8mm
 - Stripping length of the sheath: 20mm
 - Stripping length of the individual wires:5mm
- Material properties:
- Material of locking system: Plastic
 - Material of contact: copper alloy
 - Contact plating: Au
 - Material of housing: PA
 - Colour of housing: RAL 9005 (Black)
 - Material of insert: PA
- Standards: IEC 61076-2-101

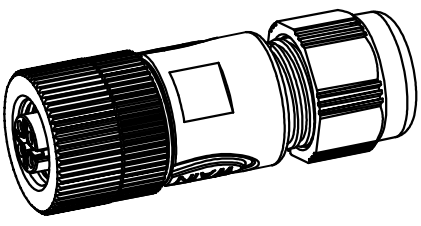

| 变更描述/Description | 日期/Date | 姓名/Name | 日期/Date | 比例 Scale | 版本 REV. | 重量 Weight | 数量 Qty. | 图号 Drawing No. | 产品代号 Part Code |
|------------------|------------|---------|------------|-------------|------------|--------------|------------|-------------------|-------------------|
| 标准件 | 17.09.2014 | ZM LIN | 17.09.2014 | 1:1 | V1.0 | - | - | M12P-F0XA-T-DX | |
| 审核 | 17.09.2014 | YY LUO | 17.09.2014 | | | | | | |
| 工艺 | - | - | - | | | | | | |

| 插针数 | 料号 | 产品代号 | 电缆直径(D) | 重量 |
|-----|---------------|----------------|---------|-------|
| 3 | 1630034213101 | M12P-F03A-T-D6 | 4-6mm | 27.9g |
| 3 | 1630034213102 | M12P-F03A-T-D8 | 6-8mm | 27.7g |
| 4 | 1630044213101 | M12P-F04A-T-D6 | 4-6mm | 28.6g |
| 4 | 1630044213102 | M12P-F04A-T-D8 | 6-8mm | 28.4g |
| 5 | 1630054213101 | M12P-F05A-T-D6 | 4-6mm | 30.4g |
| 5 | 1630054213102 | M12P-F05A-T-D8 | 6-8mm | 30.2g |

| 表面处理 Finish | 材料 Material | 比例 Scale | 版本 REV. | 重量 Weight | 数量 Qty. |
|----------------|----------------|-------------|------------|--------------|------------|
| - | - | 1:1 | V1.0 | - | - |

| 图号 Drawing No. | 产品代号 Part Code |
|-------------------|-------------------|
| - | M12P-F0XA-T-DX |

| 图号 Drawing No. | 产品代号 Part Code |
|-------------------|-------------------|
| - | M12P-F0XA-T-DX |

| 图号 Drawing No. | 产品代号 Part Code |
|-------------------|-------------------|
| - | M12P-F0XA-T-DX |